

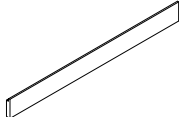

| MATERIAL LIST | | | | | |
|---------------|---|------------------------------|------|--------------------------|--------|
| PART CALLOUT: | PART: | DESCRIPTION: | QTY: | BOXED? | PACK # |
| (A) |  | WALL CLEAT | 3 | <input type="checkbox"/> | |
| (B) |  | X-217-129 - LEFT BACK PANEL | 1 | <input type="checkbox"/> | |
| (C) |  | X-217-129 - RIGHT BACK PANEL | 1 | <input type="checkbox"/> | |
| (D) |  | X-218 - LUGGAGE BENCH | 1 | <input type="checkbox"/> | |
| (E) |  | X-219 - TV CABINET | 1 | <input type="checkbox"/> | |
| PACKED BY: | EMPLOYEE ID#: _____ | | | | |

| HARDWARE LIST | | | | | | |
|---------------|---|----------------|--------------------------|------|--------------------------|--------|
| PART CALLOUT: | PART: | ARTONE PART #: | DESCRIPTION: | QTY: | BOXED? | PACK # |
| (1) |  | XX-13993 | 1/4-20 x 50mm BLACK BOLT | 2 | <input type="checkbox"/> | |
| (2) |  | X-662 | ALIGNMENT DOWEL | 2 | <input type="checkbox"/> | |
| (3) |  | 70328 | #8 x 5/8" (PPH) SCREW | 5 | <input type="checkbox"/> | |
| (4) |  | XX-13012 | WIRE MANAGEMENT CLIP | 2 | <input type="checkbox"/> | |
| PACKED BY: | EMPLOYEE ID#: _____ | | | | | |

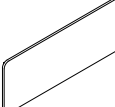
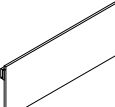
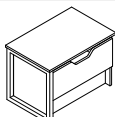
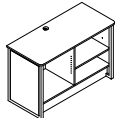
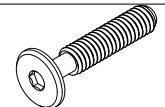

1089 Allen Street
 Jamestown, NY 14701
 Phone 716.664.2232
 Fax 716.664.1511

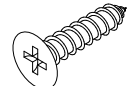
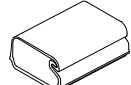

DESK UNIT
 (X-217-100, X-218, X-219)
 HARDWARE MATERIAL

| |
|----------------------------|
| Original Issue: 2/20/26 |
| Scale: N/A |
| Job No.: SL.417 |
| Drawn: AB |
| Drawing: HRDW/MATL |

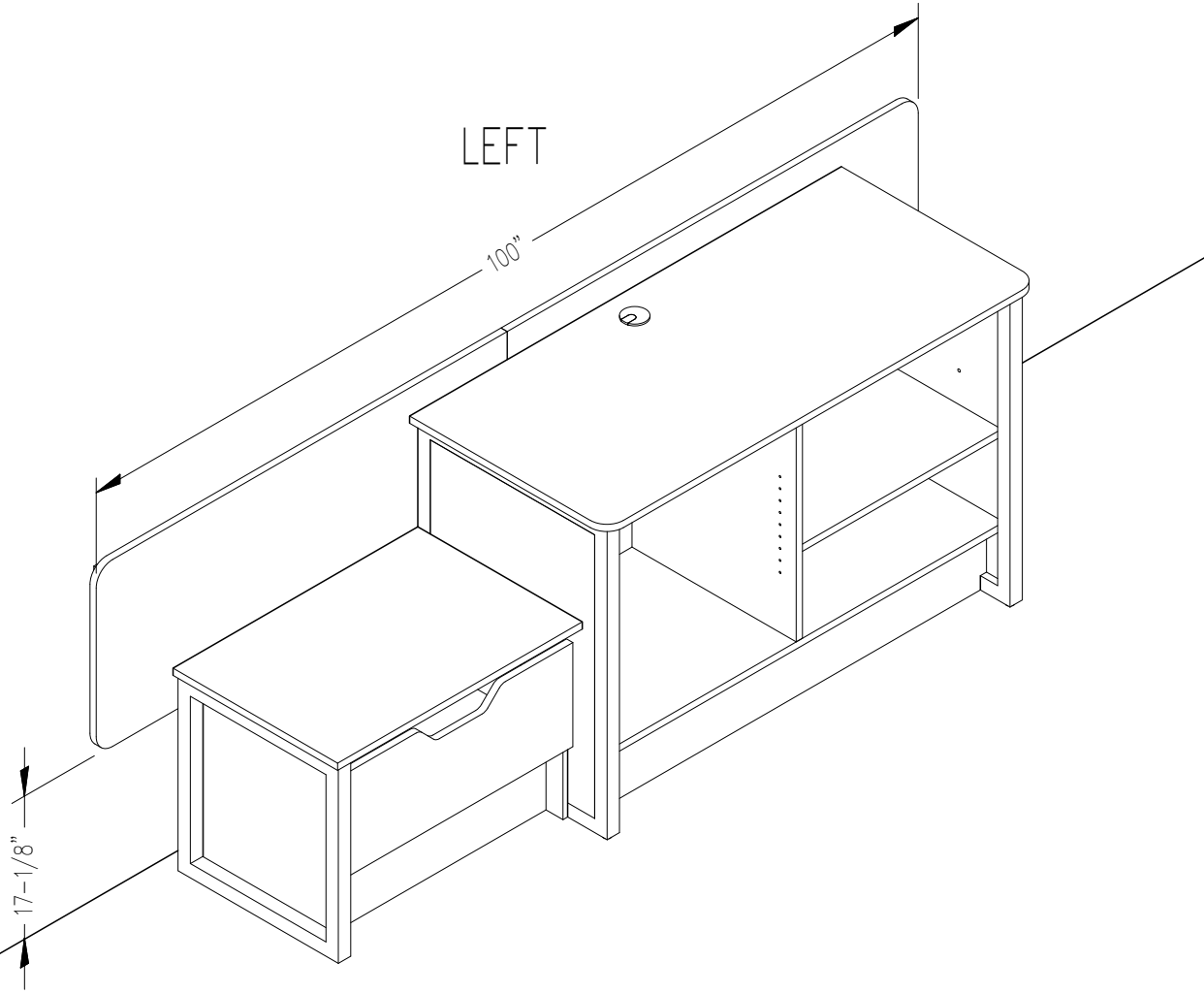

OR

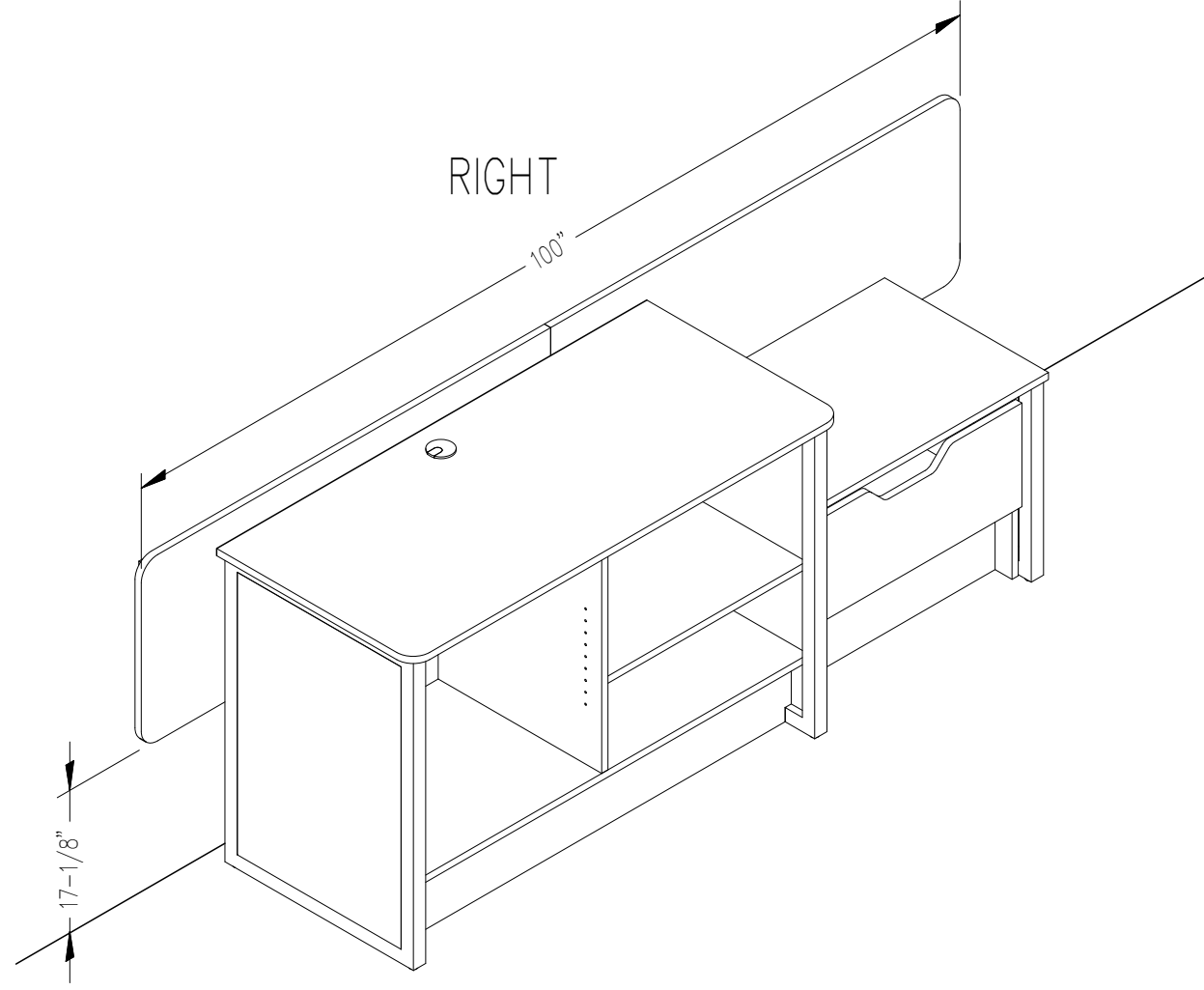

1089 Allen Street
 Jamestown, NY 14701
 Phone 716.664.2232
 Fax 716.664.1511

ARTONE
 FURNITURE BY DESIGN

DESK UNIT
 (X-217-100, X-218, X-219)
 FULLY ASSEMBLED

Original Issue:
 2/20/26
 Scale:
 AS NOTED
 Job No.:
 SL. 417
 Drawn:
 AB

Drawing:
 FULL ASSY

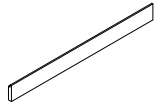
| PART CALLOUT: | PART: | DESCRIPTION: | QTY: |
|---------------|---|--------------|------|
| (A) |  | WALL CLEAT | 3 |

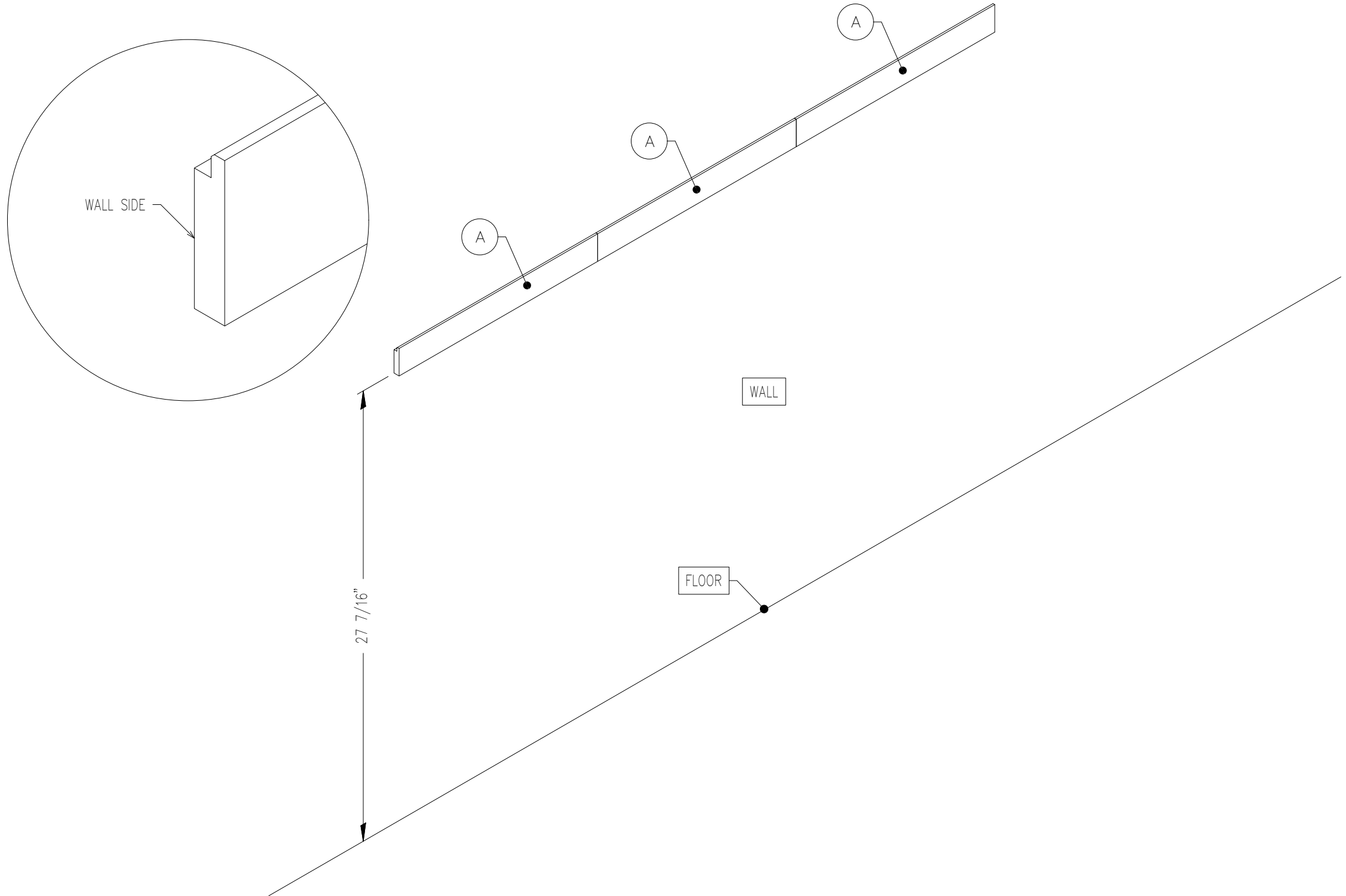



1089 Allen Street
 Jamestown, NY 14701
 Phone 716.664.2232
 Fax 716.664.1511

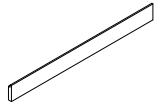
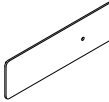
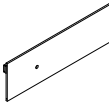

DESK UNIT
 (X-217-100, X-218, X-219)
 STEP 1

| |
|----------------------------|
| Original Issue: 2/20/26 |
| Scale: AS NOTED |
| Job No.: SL.417 |
| Drawn: AB |
| Drawing: STEP 1 |

| PART CALLOUT: | PART: | DESCRIPTION: | QTY: |
|---------------|---|------------------------------|------|
| (A) |  | WALL CLEAT | 3 |
| (B) |  | X-217-129 - LEFT BACK PANEL | 1 |
| (C) |  | X-217-129 - RIGHT BACK PANEL | 1 |
| (2) |  | ALIGNMENT DOWEL | 2 |

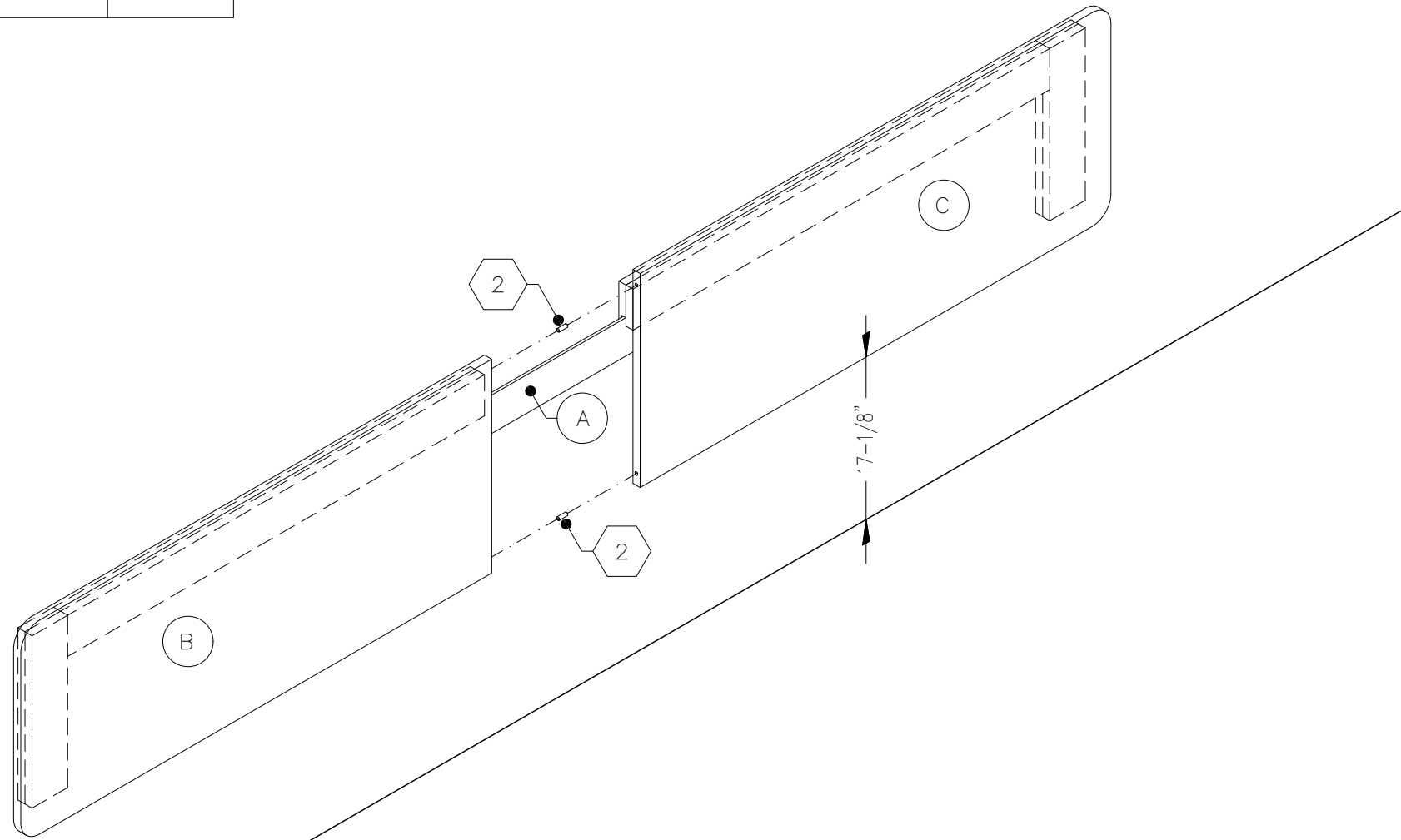

1089 Allen Street
 Jamestown, NY 14701
 Phone 716.664.2232
 Fax 716.664.1511

ARTONE
 FURNITURE BY DESIGN

DESK UNIT
 (X-217-100, X-218, X-219)
 STEP 2

| |
|----------------------------|
| Original Issue: 2/20/26 |
| Scale: AS NOTED |
| Job No.: SL.417 |
| Drawn: AB |
| Drawing: STEP 2 |

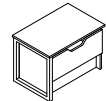
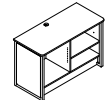
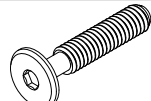
| PART CALLOUT: | PART: | DESCRIPTION: | QTY: |
|---------------|---|--------------------------|------|
| D |  | X-218 - LUGGAGE BENCH | 1 |
| E |  | X-219 - TV CABINET | 1 |
| 1 |  | 1/4-20 x 50mm BLACK BOLT | 2 |

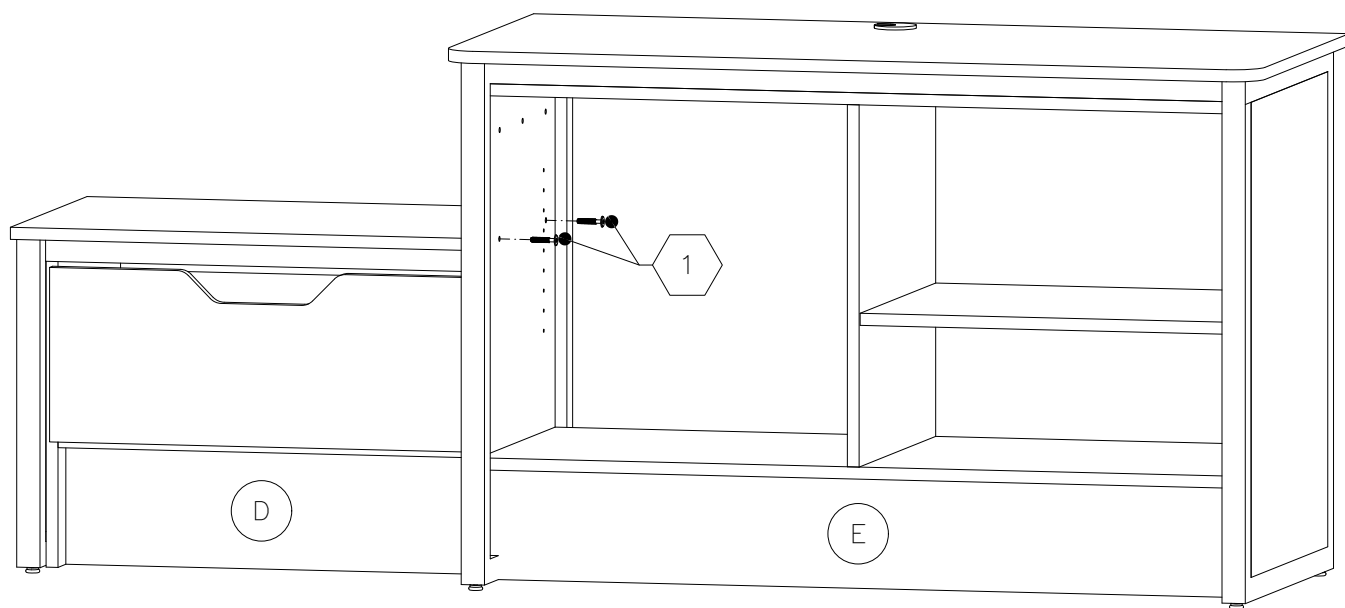

1089 Allen Street
 Jamestown, NY 14701
 Phone 716.664.2232
 Fax 716.664.1511

ARTONE
 FURNITURE BY DESIGN

DESK UNIT
 (X-217-100, X-218, X-219)
 STEP 3



Original Issue:
 2/20/26

Scale:
 AS NOTED

Job No.:
 SL.417

Drawn:
 AB

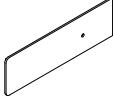
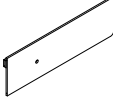
Drawing:
 STEP 3

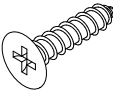
| PART CALLOUT: | PART: | DESCRIPTION: | QTY: |
|---------------|---|------------------------------|------|
| B |  | X-217-129 - LEFT BACK PANEL | 1 |
| C |  | X-217-129 - RIGHT BACK PANEL | 1 |
| E |  | X-219 - TV CABINET | 1 |
| 3 |  | #8 x 5/8" (PPH) SCREW | 5 |

ATTACH **E** TO **B** & **C** WITH **3**

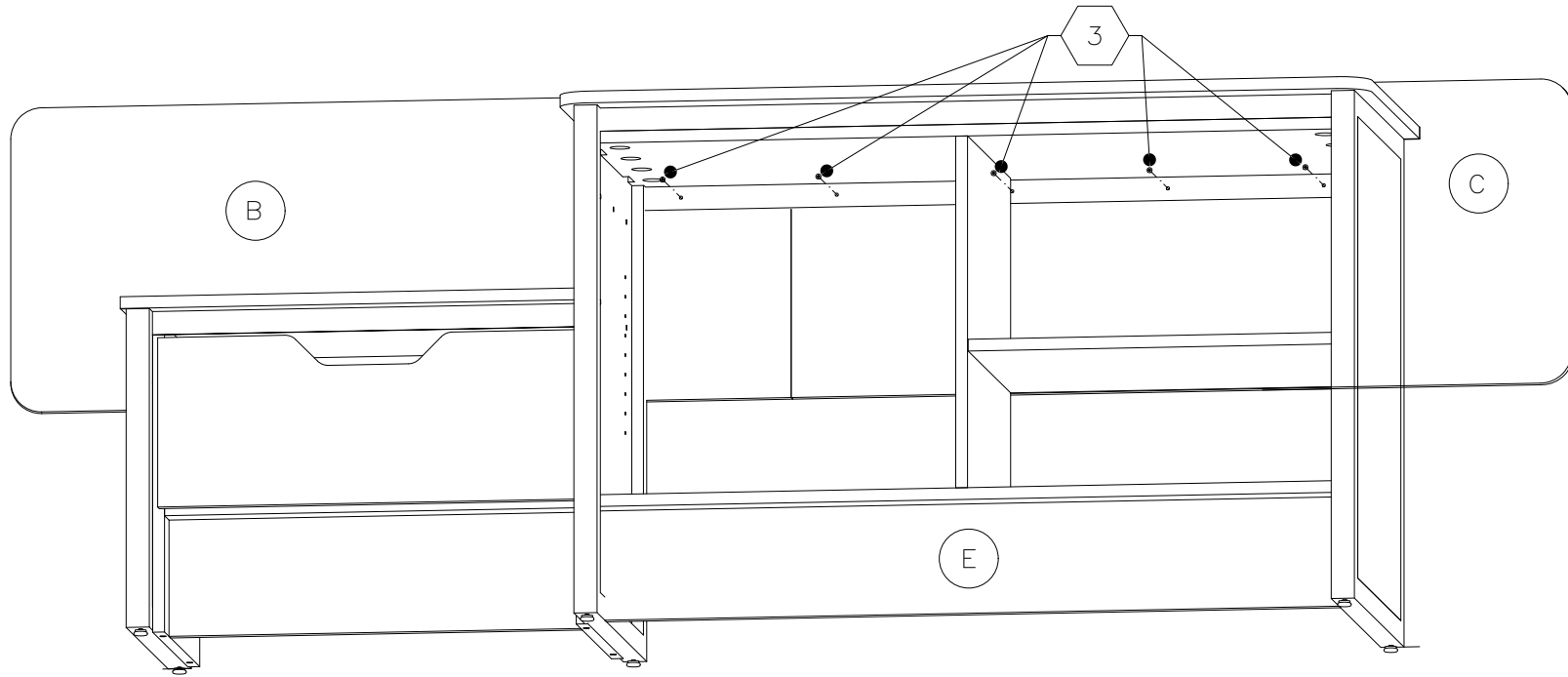

1089 Allen Street
 Jamestown, NY 14701
 Phone 716.664.2232
 Fax 716.664.1511



DESK UNIT
 (X-217-100, X-218, X-219)
 STEP 4

| |
|----------------------------|
| Original Issue: 2/20/26 |
| Scale: AS NOTED |
| Job No.: SL.417 |
| Drawn: AB |
| Drawing: STEP 4 |

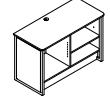
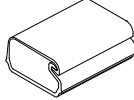
| PART CALLOUT: | PART: | DESCRIPTION: | QTY: |
|---------------|---|----------------------|------|
| E |  | X-219 - TV CABINET | 1 |
| 4 |  | WIRE MANAGEMENT CLIP | 2 |

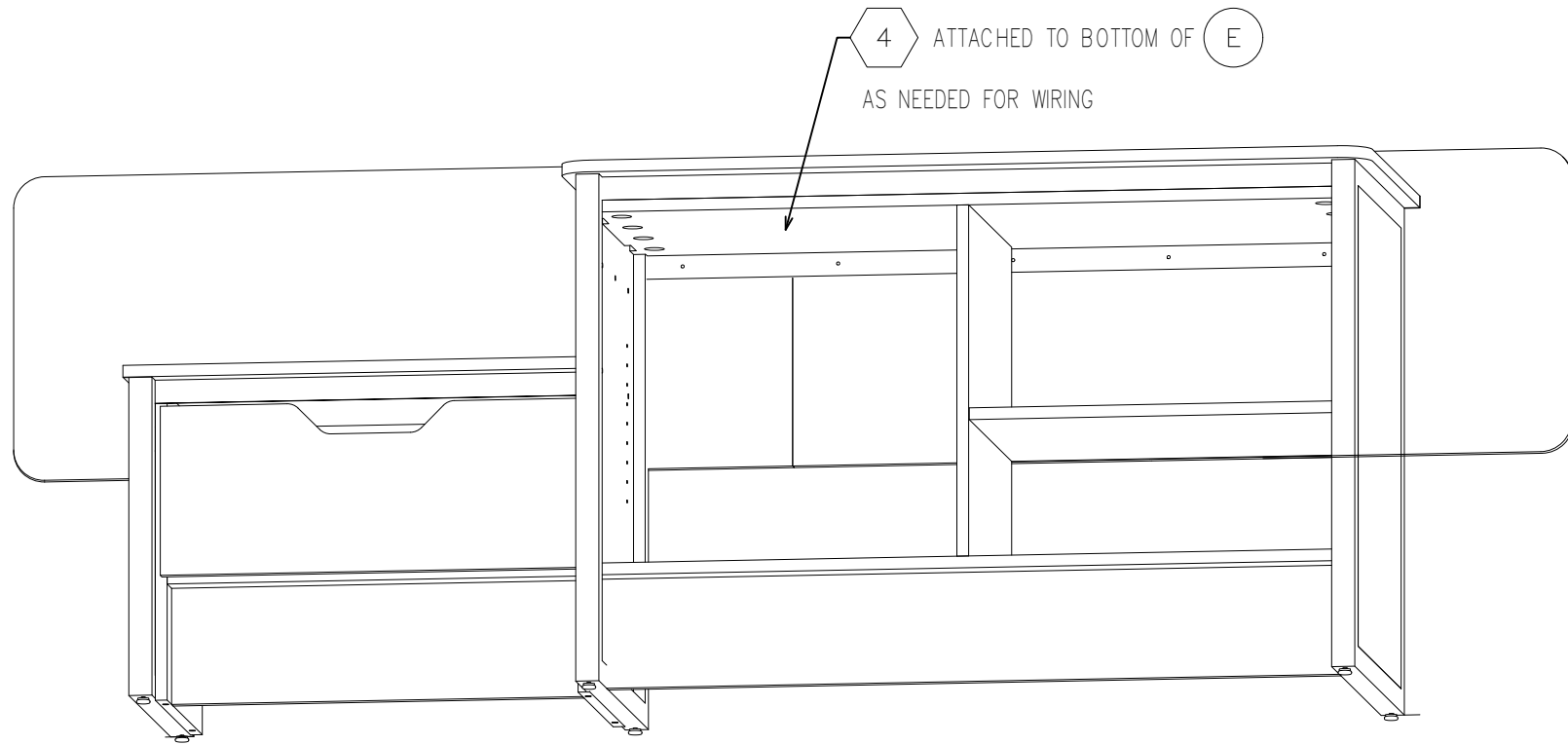

1089 Allen Street
 Jamestown, NY 14701
 Phone 716.664.2232
 Fax 716.664.1511

ARTONE
 FURNITURE BY DESIGN

DESK UNIT
 (X-217-100, X-218, X-219)
 STEP 5

| |
|----------------------------|
| Original Issue: 2/20/26 |
| Scale: AS NOTED |
| Job No.: SL.417 |
| Drawn: AB |
| Drawing: STEP 5 |

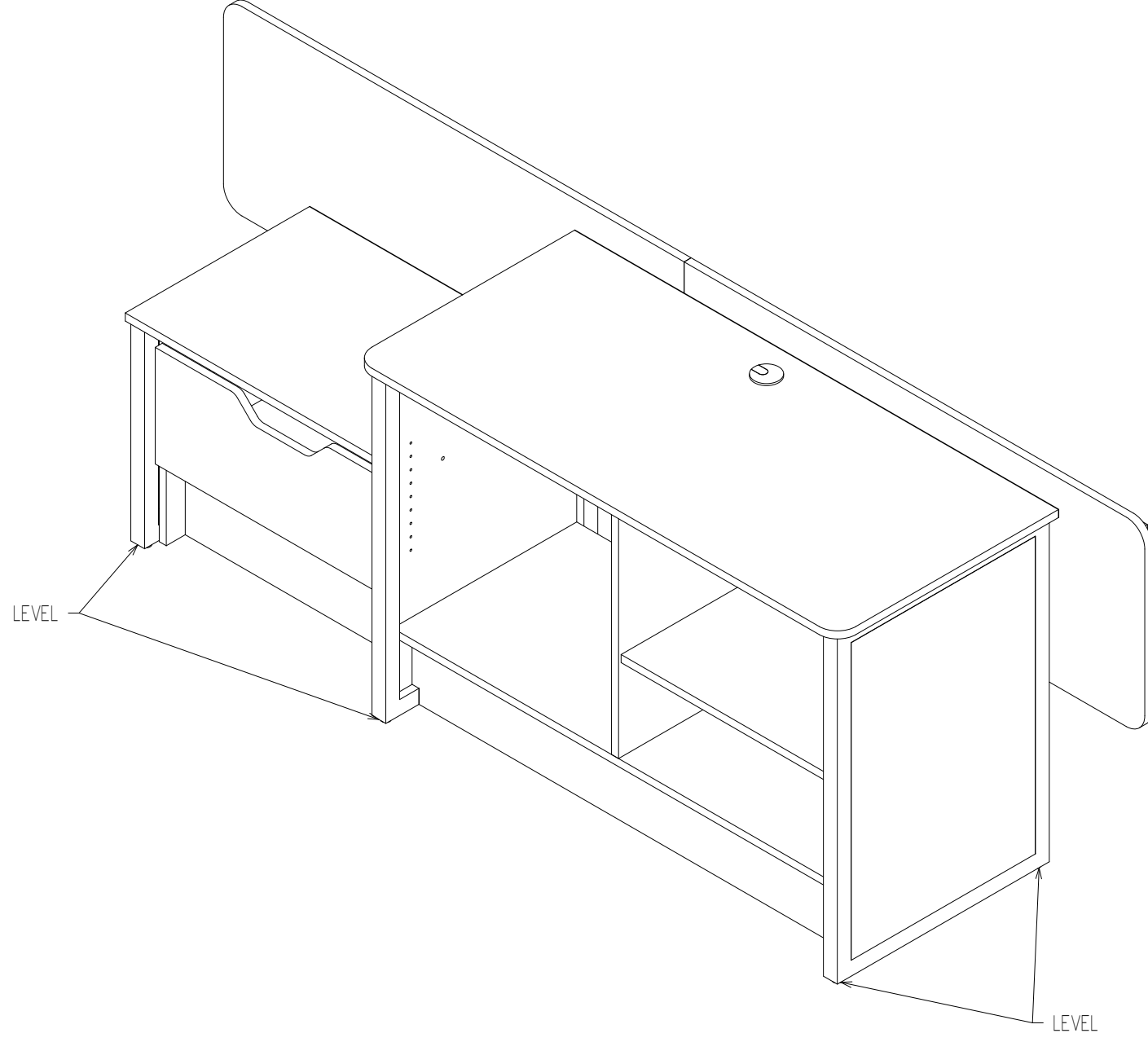

1089 Allen Street
 Jamestown, NY 14701
 Phone 716.664.2232
 Fax 716.664.1511

ARTONE
 FURNITURE BY DESIGN

DESK UNIT
 (X-217-100, X-218, X-219)
 STEP 6

| |
|----------------------------|
| Original Issue: 2/20/26 |
| Scale: AS NOTED |
| Job No.: SL.417 |
| Drawn: AB |

| |
|--------------------|
| Drawing: STEP 6 |
|--------------------|