

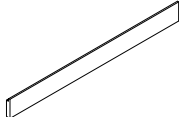

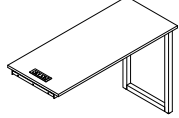

MATERIAL LIST					
PART CALLOUT:	PART:	DESCRIPTION:	QTY:	BOXED?	PACK #
(A)		WALL CLEAT	3	<input type="checkbox"/>	
(B)		X-216 - DESK	1	<input type="checkbox"/>	
(C)		X-217-100 - LEFT BACK PANEL	1	<input type="checkbox"/>	
(D)		X-217-100 - RIGHT BACK PANEL	1	<input type="checkbox"/>	
(E)		X-219 - TV CABINET	1	<input type="checkbox"/>	
PACKED BY:	EMPLOYEE ID#: _____				

HARDWARE LIST						
PART CALLOUT:	PART:	ARTONE PART #:	DESCRIPTION:	QTY:	BOXED?	PACK #
(1)		XX-13993	1/4-20 x 50mm BLACK BOLT	3	<input type="checkbox"/>	
(2)		XX-14045	1/4-20 HEX NUT	3	<input type="checkbox"/>	
(3)		XX-14046	1/4-20 WASHER	3	<input type="checkbox"/>	
(4)		X-662	ALIGNMENT DOWEL	2	<input type="checkbox"/>	
(5)		70328	#8 x 5/8" (PPH) SCREW	5	<input type="checkbox"/>	
(6)		XX-13012	WIRE MANAGEMENT CLIP	2	<input type="checkbox"/>	
PACKED BY:	EMPLOYEE ID#: _____					

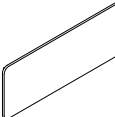
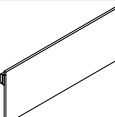
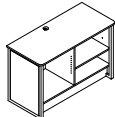
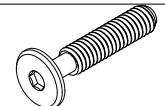

1089 Allen Street
 Jamestown, NY 14701
 Phone 716.664.2232
 Fax 716.664.1511

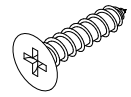
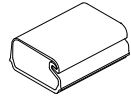

DESK UNIT
 (X-216, X-217-100, X-219)
 HARDWARE/MATERIAL

Original Issue:
2/20/26

Scale:
N/A

Job No.:
SL. 417

Drawn:
AB

Drawing:
HRDW/MATL

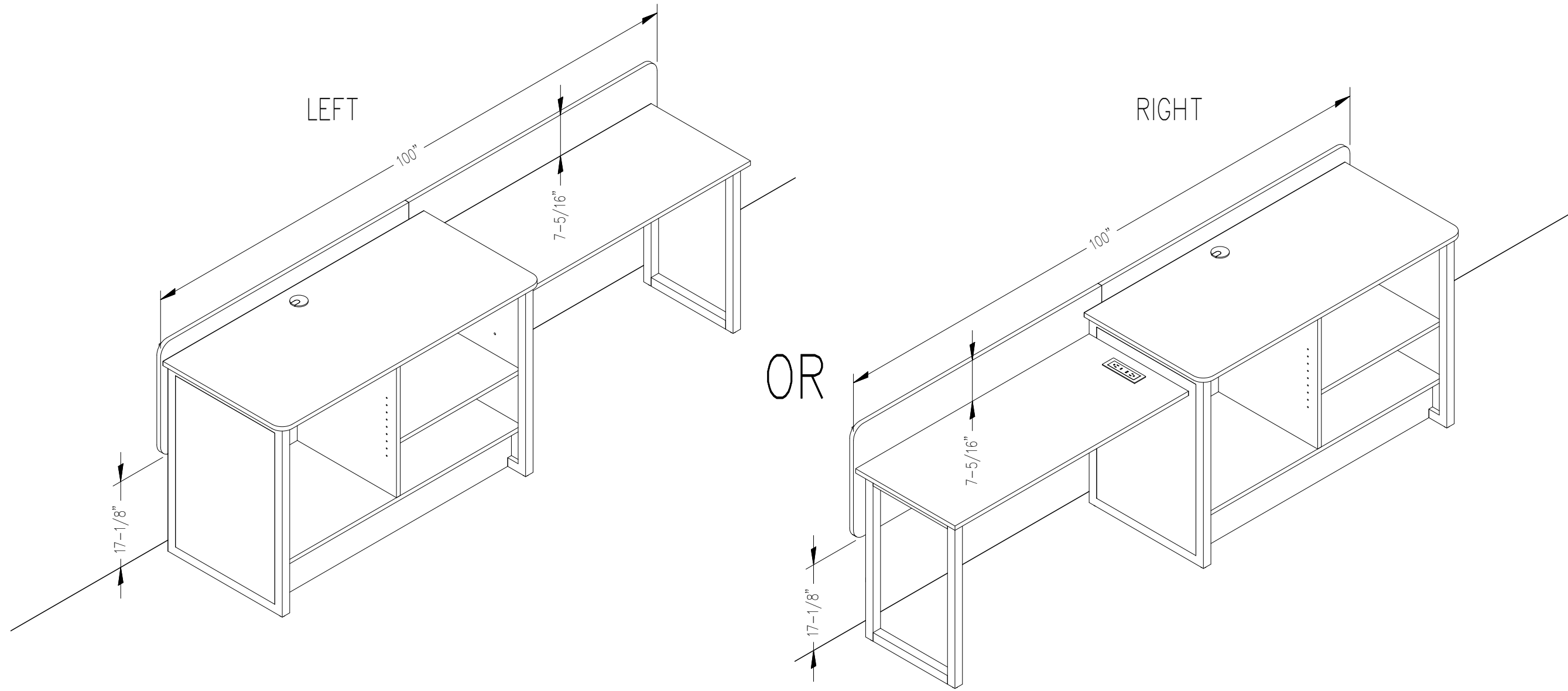

1089 Allen Street
 Jamestown, NY 14701
 Phone 716.664.2232
 Fax 716.664.1511

ARTONE
 FURNITURE BY DESIGN

DESK UNIT
 (X-216, X-217-100, X-219)
 FULLY ASSEMBLED

Original Issue:
 2/20/26
 Scale:
 AS NOTED
 Job No.:
 SL. 417
 Drawn:
 AB

Drawing:
 FULL ASSY

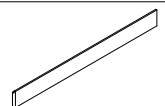
PART CALLOUT:	PART:	DESCRIPTION:	QTY:
A		WALL CLEAT	3

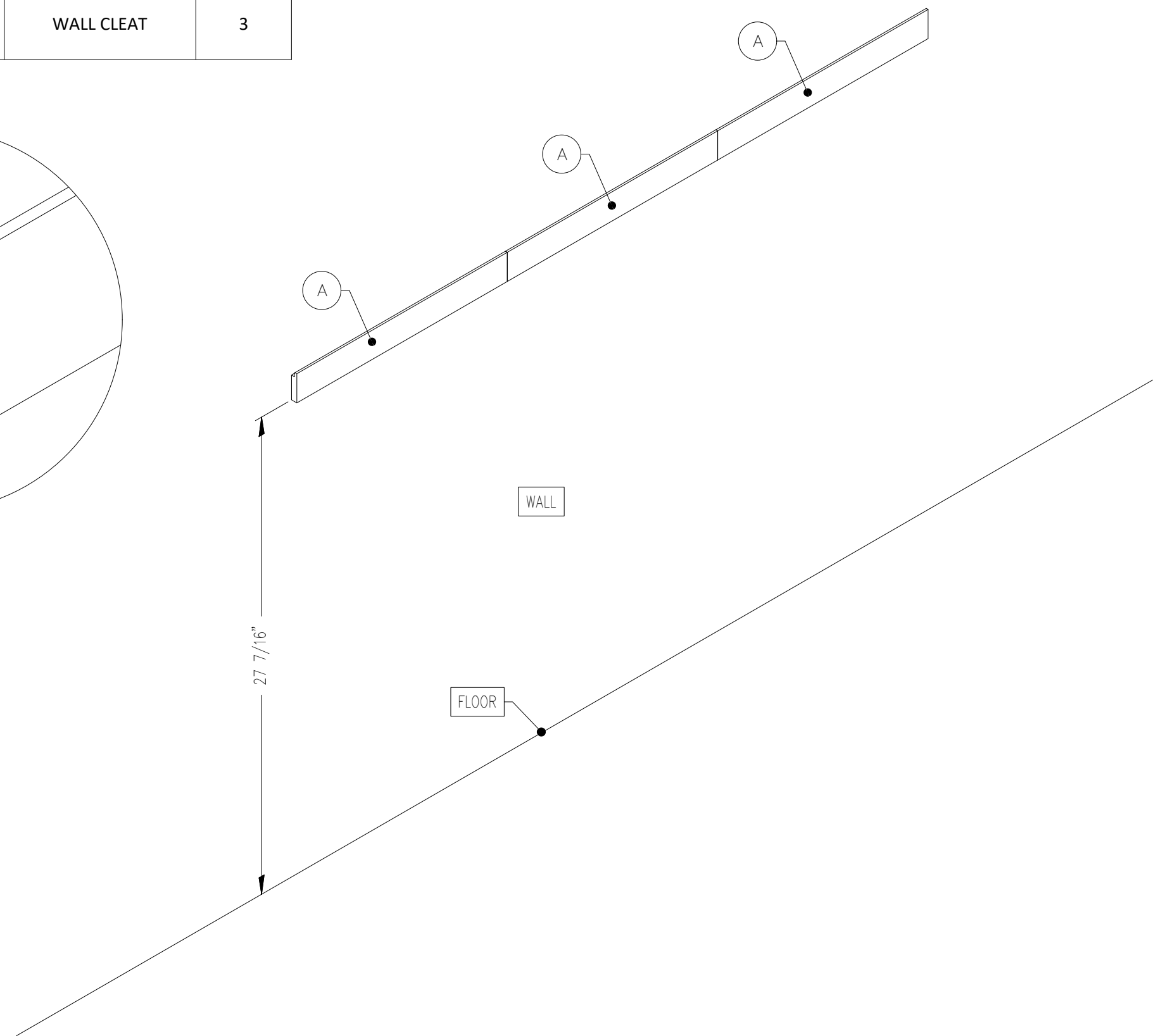
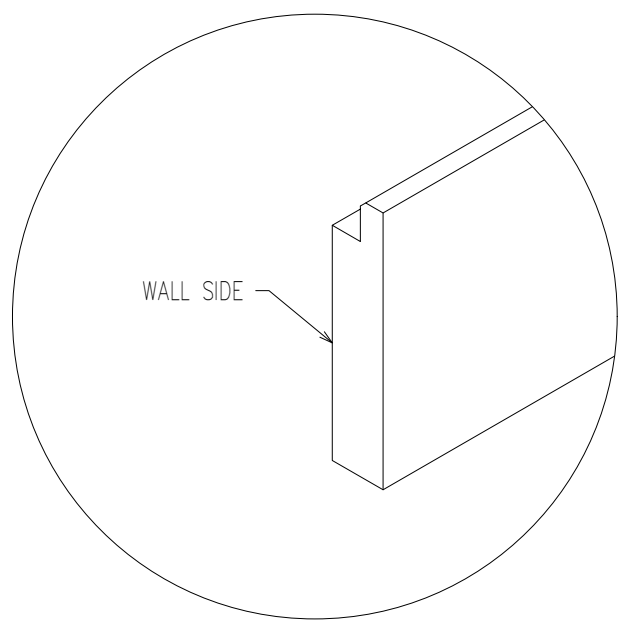



1089 Allen Street
 Jamestown, NY 14701
 Phone 716.664.2232
 Fax 716.664.1511

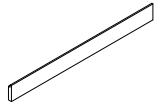
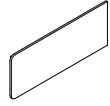
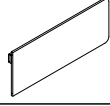

DESK UNIT
 (X-216, X-217-100, X-219)
 STEP 1

Original Issue: 2/20/26
Scale: AS NOTED
Job No.: SL.417
Drawn: AB
Drawing: STEP 1

PART CALLOUT:	PART:	DESCRIPTION:	QTY:
(A)		WALL CLEAT	3
(C)		X-217-100 - LEFT BACK PANEL	1
(D)		X-217-100 - RIGHT BACK PANEL	1
(4)		ALIGNMENT DOWEL	2

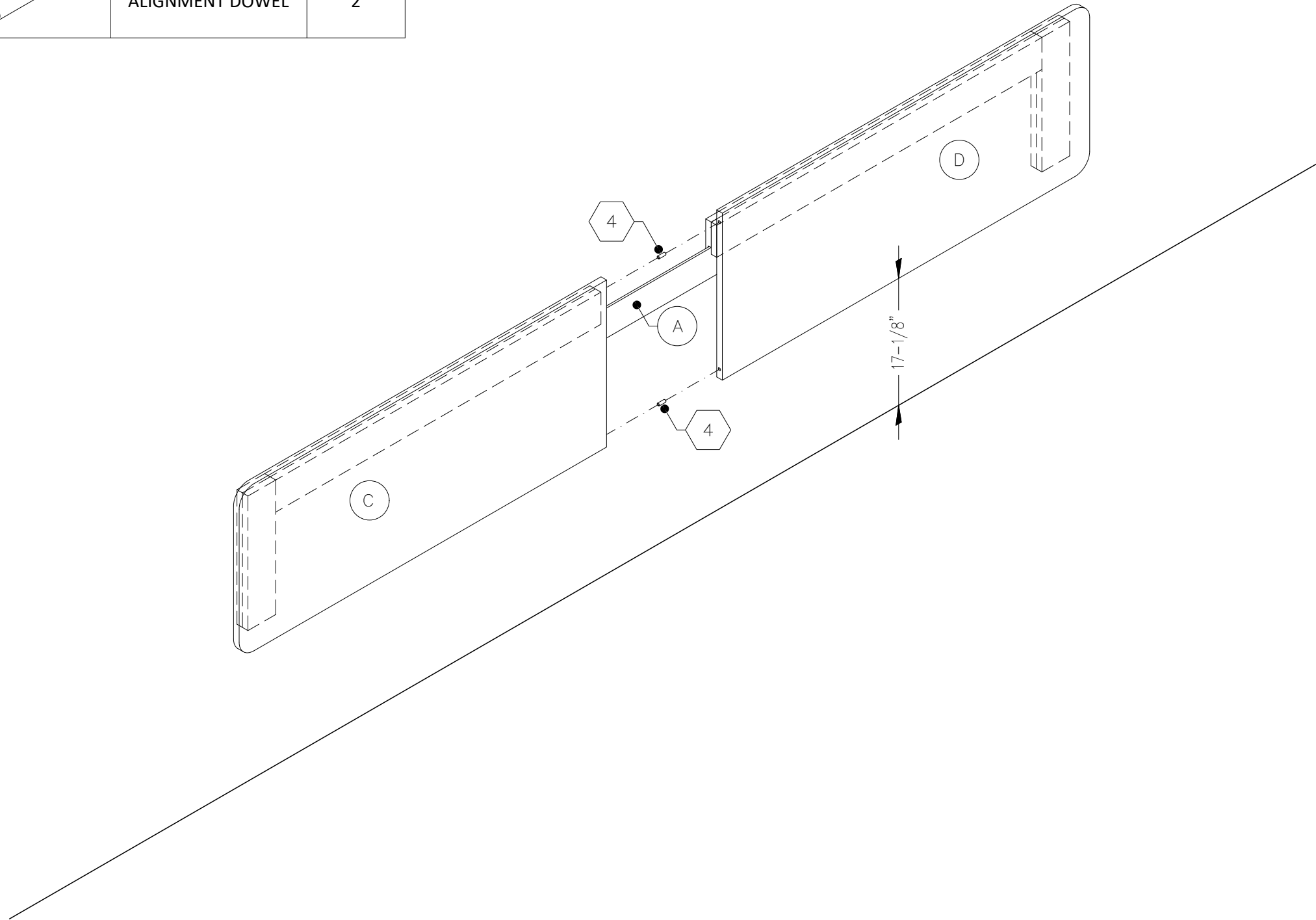





1089 Allen Street
 Jamestown, NY 14701
 Phone 716.664.2232
 Fax 716.664.1511

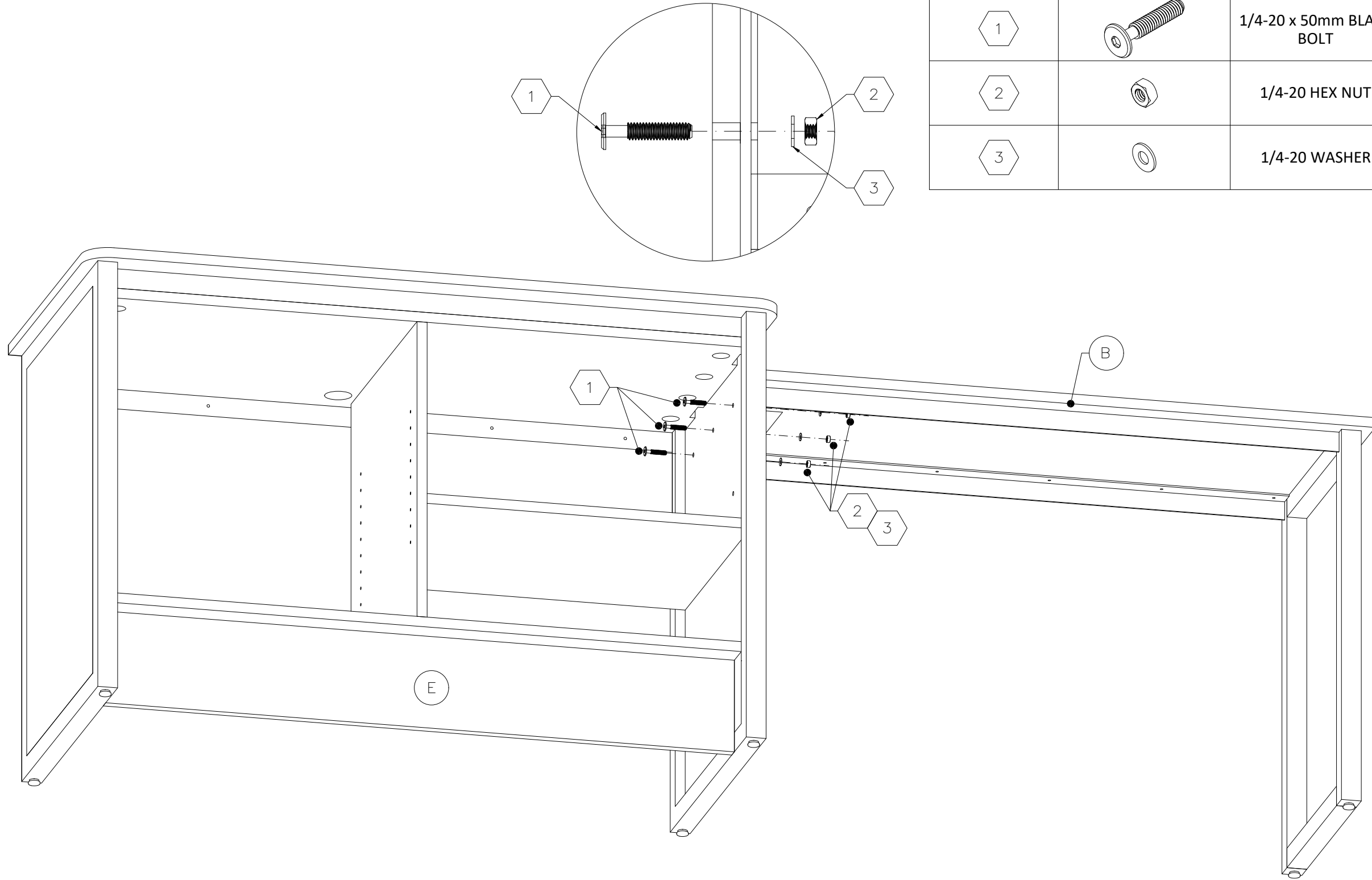

DESK UNIT
 (X-216, X-217-100, X-219)
 STEP 2

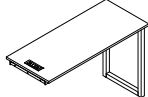
Original Issue: 2/20/26
Scale: AS NOTED
Job No.: SL.417
Drawn: AB
Drawing: STEP 2

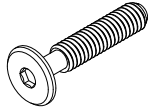

PART CALLOUT:	PART:	DESCRIPTION:	QTY:
(B)		X-216 - DESK	1
(E)		X-219 - TV CABINET	1
(1)		1/4-20 x 50mm BLACK BOLT	3
(2)		1/4-20 HEX NUT	3
(3)		1/4-20 WASHER	3



1089 Allen Street
 Jamestown, NY 14701
 Phone 716.664.2232
 Fax 716.664.1511

ARTONE
 FURNITURE BY DESIGN

DESK UNIT
 (X-216, X-217-100, X-219)
 STEP 3

Original Issue: 2/20/26
Scale: AS NOTED
Job No.: SL.417
Drawn: AB
Drawing: STEP 3

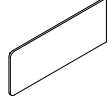
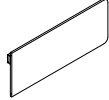
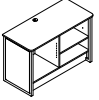
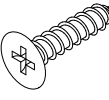
PART CALLOUT:	PART:	DESCRIPTION:	QTY:
C		X-217-100 - LEFT BACK PANEL	1
D		X-217-100 - RIGHT BACK PANEL	1
E		X-219 - TV CABINET	1
5		#8 x 5/8" (PPH) SCREW	5

ATTACH (F) TO (C) & (D) WITH (5)

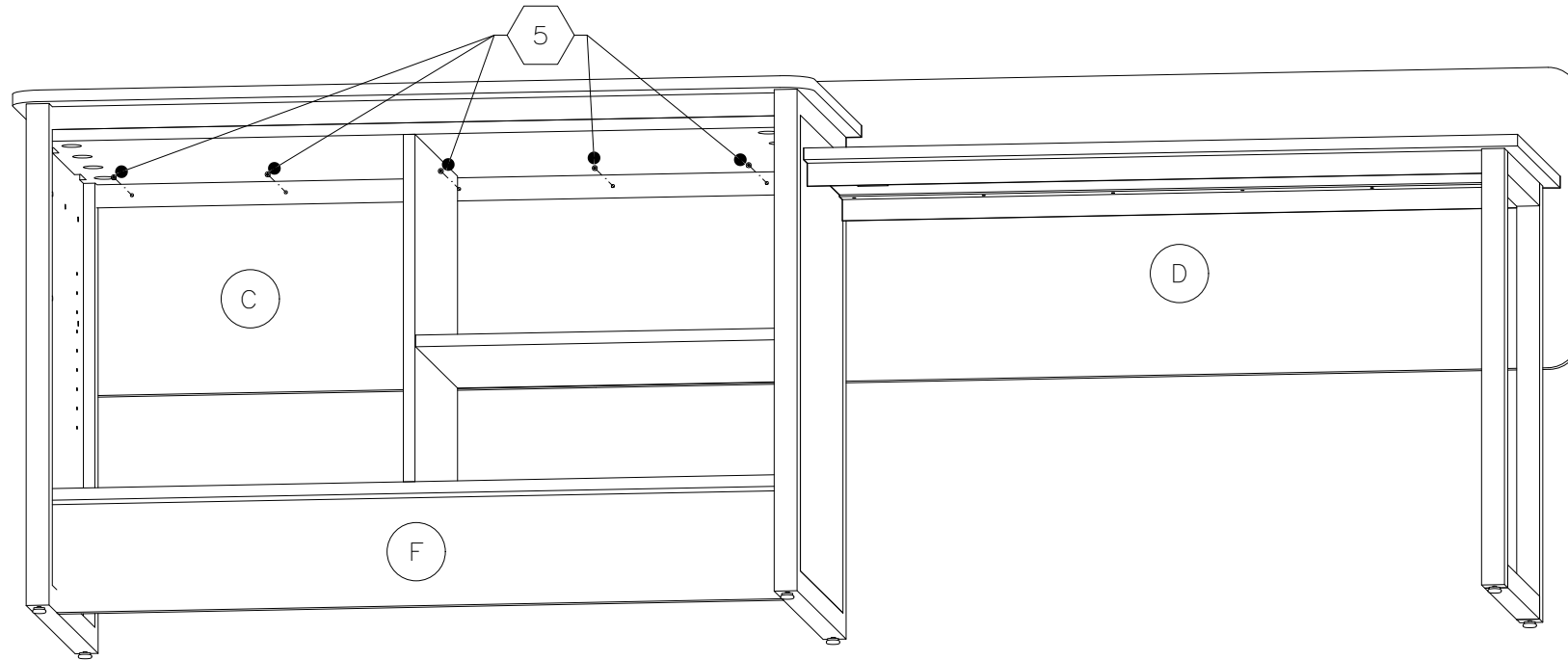

1089 Allen Street
 Jamestown, NY 14701
 Phone 716.664.2232
 Fax 716.664.1511



DESK UNIT
 (X-216, X-217-100, X-219)
 STEP 4

Original Issue:	2/20/26
Scale:	AS NOTED
Job No.:	SL.417
Drawn:	AB
Drawing:	STEP 4

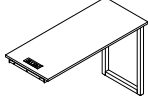
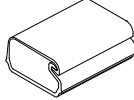
PART CALLOUT:	PART:	DESCRIPTION:	QTY:
(B)		X-216 - DESK	1
6		WIRE MANAGEMENT CLIP	2

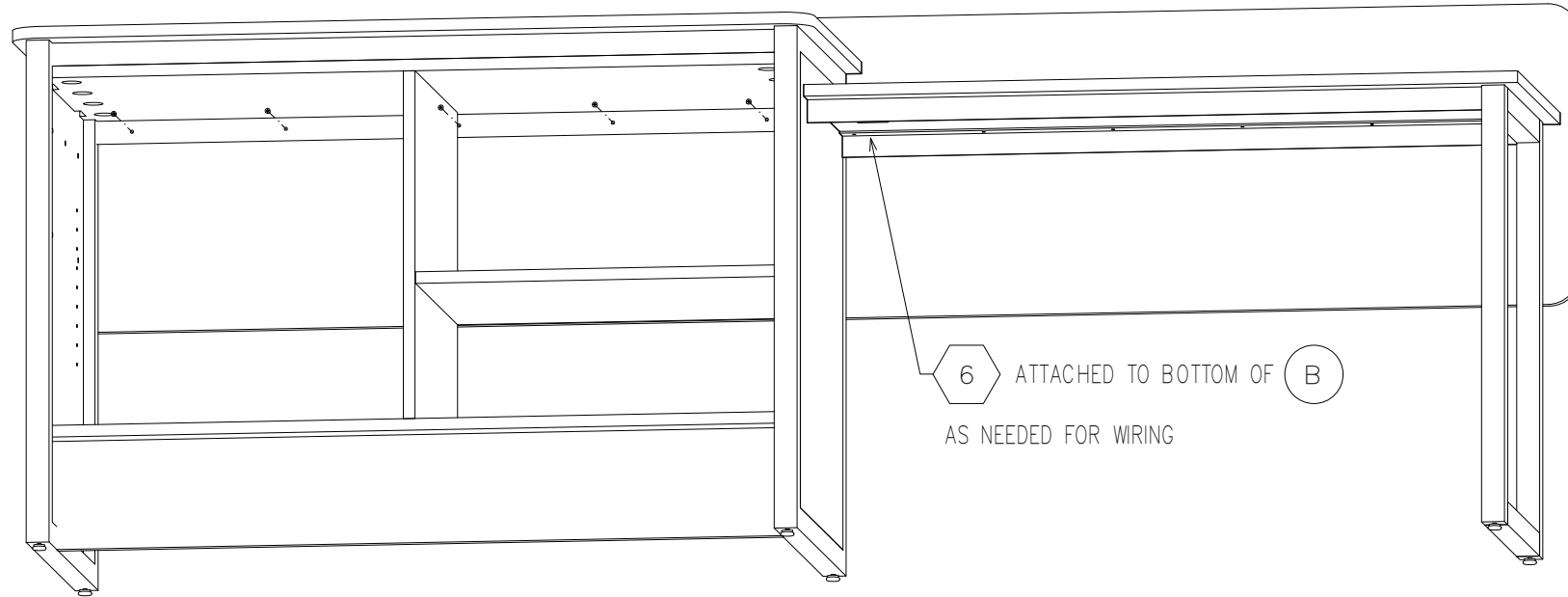

1089 Allen Street
Jamestown, NY 14701
Phone 716.664.2232
Fax 716.664.1511

ARTONE
FURNITURE BY DESIGN

DESK UNIT
(X-216, X-217-100, X-219)
STEP 5

Original Issue:
2/20/26
Scale:
AS NOTED
Job No.:
SL.417
Drawn:
AB

Drawing:
STEP 5

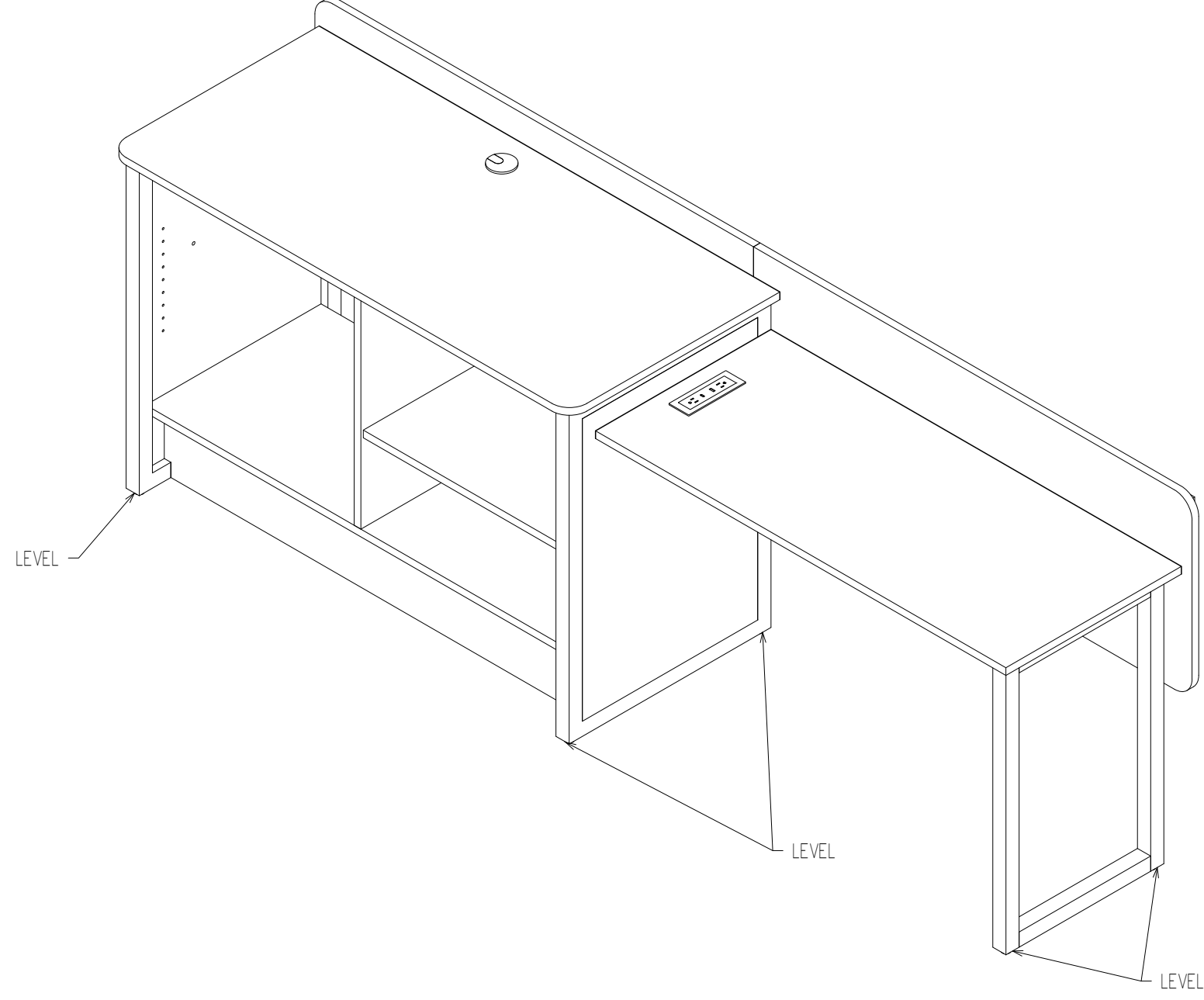

1089 Allen Street
 Jamestown, NY 14701
 Phone 716.664.2232
 Fax 716.664.1511

ARTONE
 FURNITURE BY DESIGN

DESK UNIT
 (X-216, X-217-100, X-219)
 STEP 5

Original Issue:
 2/20/26
 Scale:
 AS NOTED
 Job No.:
 SL. 417
 Drawn:
 AB

Drawing:
 STEP 6